

1200X1800MM
FAB SURFACE

SIZE & THICKNESS

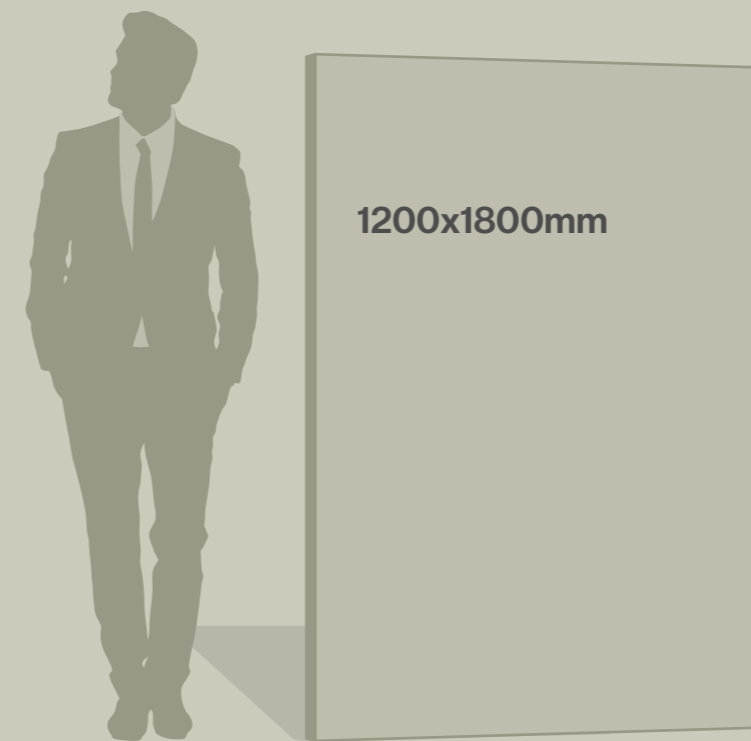

EXTENSIVE SIZE LIMITLESS APPLICATIONS

Explore ceaseless opportunities to enable a grand decor style with the extensive 1200x1800mm size of Fab Surface, offering spaces a fine aesthetics.

ADAPTABLE SIZE

The grand size of the collection is versatile on the contrary and allows one to explore decor ideas and execute them to perfection.

RESOURCEFUL APPLICATION

The multifarious size offers versatile application possibilities for your spaces, furniture, and other tiling needs.

IMPECCABLE LAY

The variable sizes under the collection offers a seamless lay for your select spaces with less unflattering grout lines and facilitating a continuous floor and wall.

TAKING CARE MADE SIMPLE

Along with the materials like water, oil, grease, etc. we have also taken care of the elements created by the environmental conditions, like algae, which makes the surface slippery. 'Protect' surface stops the formation and development of the algae and makes it an anti-algae surface. These qualities of the 'Protect' surface make it an anti-skid in the true sense.

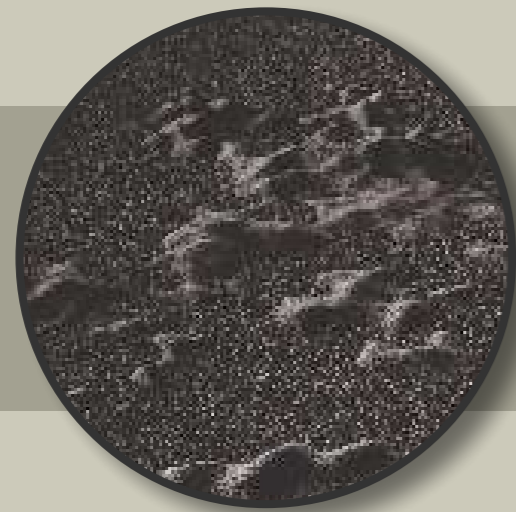

1. PROTECT SURFACE

To minimize the roughness created by the cliffs, we apply the unique micro protect-particles that cover the deep valleys creating the smoothest anti-skid surface without affecting the cliffs.

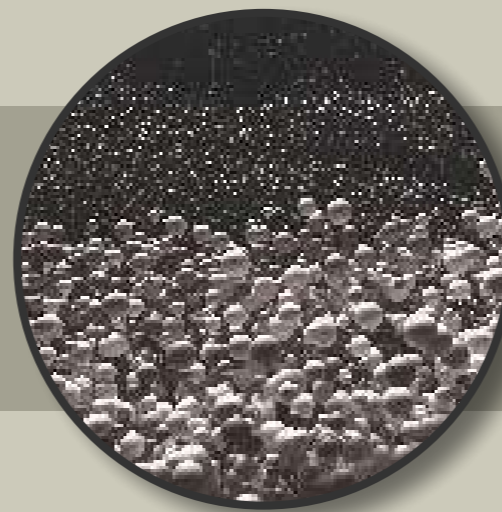

2. APPLYING THE MICRO PROTECT-PARTICLES

To create the material you need the skill of an artisan, machines and ceramic know-how, aesthetic culture and a passion for design. And you need tough and painstaking development work.



3. TRADITIONAL ANTI-SKID SURFACE

When we observe the regular anti-skid surface under a microscope, we notice higher cliffs that create valleys making the surface rough, unpleasant to touch, and difficult to clean and maintain.

PERFECT FROM BEGINNING TO END

While our control the happenings in the world outside is quite limited. we must surely take onus of safety within out own happy place. Today, one's safety. health and wellness are amongs the greatness concerns globally, and this has given us an oppurtunity to innovte, and to come up with unique solutions that either eliminate or lessen the challenges we face each day

utilizing our latest production systems, we introduce you to a technology that removes uncertainties or doubts involving safety within your home fab surface the technology helps the product surface repel any liquid and does not allow unwanted or harmful living organisms to stay or grow, This water repellent and anti-bacterial surface created with fab surface requires the lowest maintenance efforts, keeping you from second guessing your safety indoors.



LIQUID REPELLENT

STAIN RESISTANT

SCRATCH RESISTANT

FIRE RESISTANT

RESISTANT TO UV RAYS

IMPACT RESISTANT

FROST RESISTANT

ROSATA
SERIES



Tiles In Frame	Size	Finish	Thickness	Randoms
BERLIN ROCK STATUARIO	1200x 1800mm	Fab Surface	9mm	3

- 
LIQUID
REPELLENT
- 
STAIN
RESISTANT
- 
SCRATCH
RESISTANT
- 
FIRE
RESISTANT
- 
RESISTANT TO
UV RAYS
- 
IMPACT
RESISTANT
- 
FROST
RESISTANT



ROSATA
SERIES

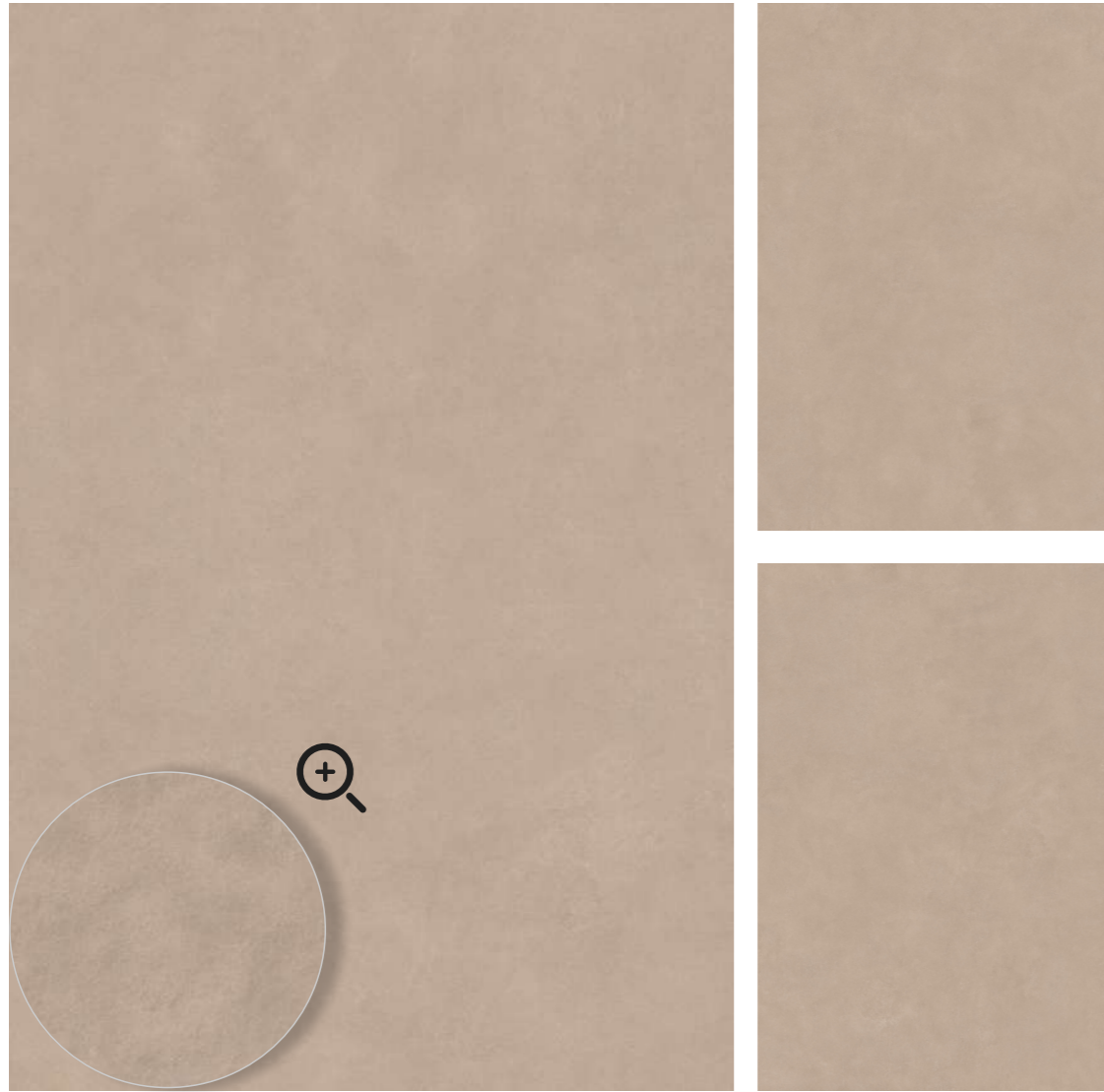

Tiles In Frame	Size	Finish	Thickness	Randoms
ROSATA AVORIO	1200x1800mm	Fab Surface	9mm	3

- 
LIQUID REPELLENT
- 
STAIN RESISTANT
- 
SCRATCH RESISTANT
- 
FIRE RESISTANT
- 
RESISTANT TO UV RAYS
- 
IMPACT RESISTANT
- 
FROST RESISTANT



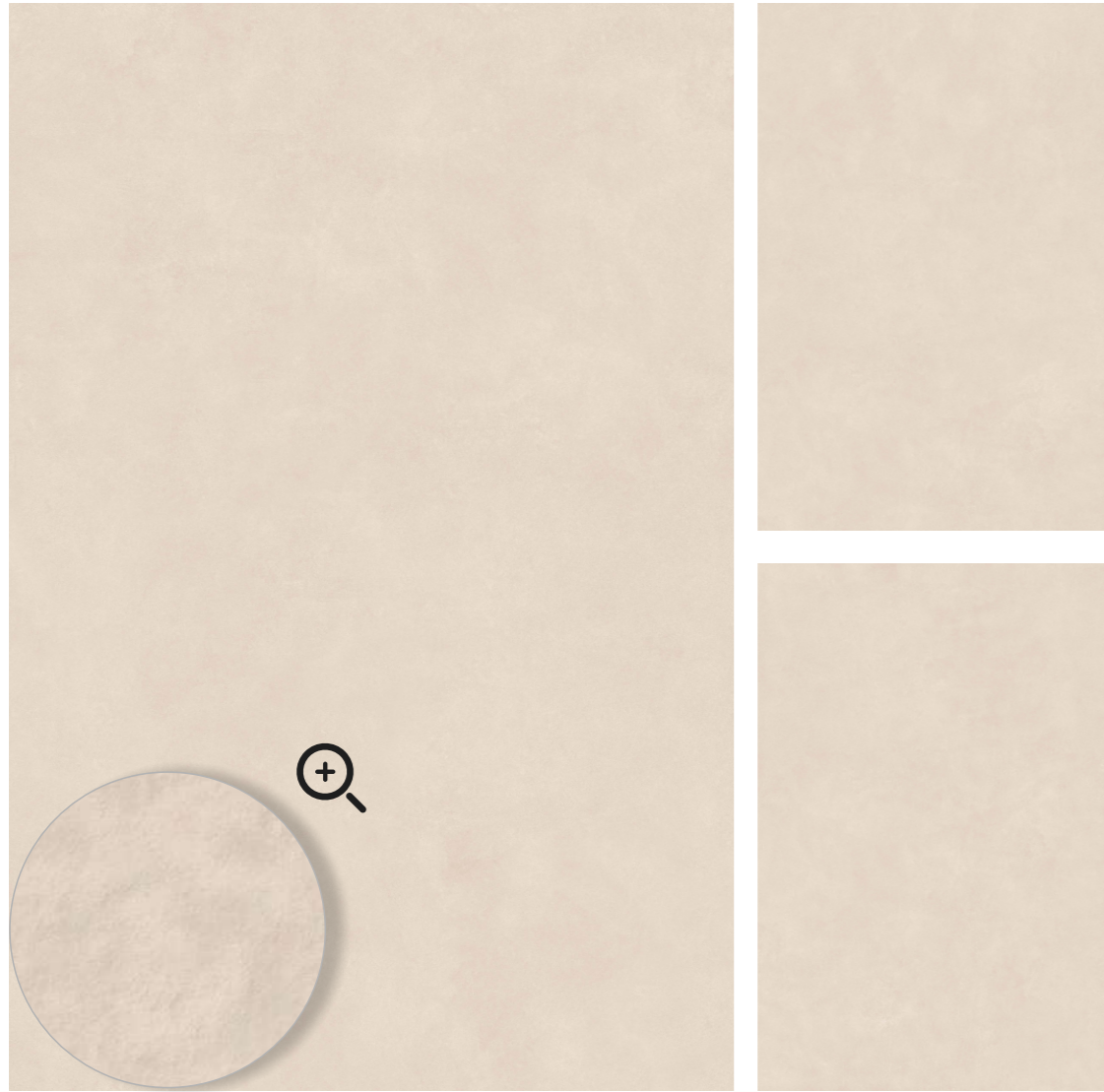

Tiles In Frame	Size	Finish	Thickness	Randoms
ROSATA TUSK	1200x 1800mm	Fab Surface	9mm	3

- 
LIQUID
REPELLENT
- 
STAIN
RESISTANT
- 
SCRATCH
RESISTANT
- 
FIRE
RESISTANT
- 
RESISTANT TO
UV RAYS
- 
IMPACT
RESISTANT
- 
FROST
RESISTANT



ROSATA
SERIES

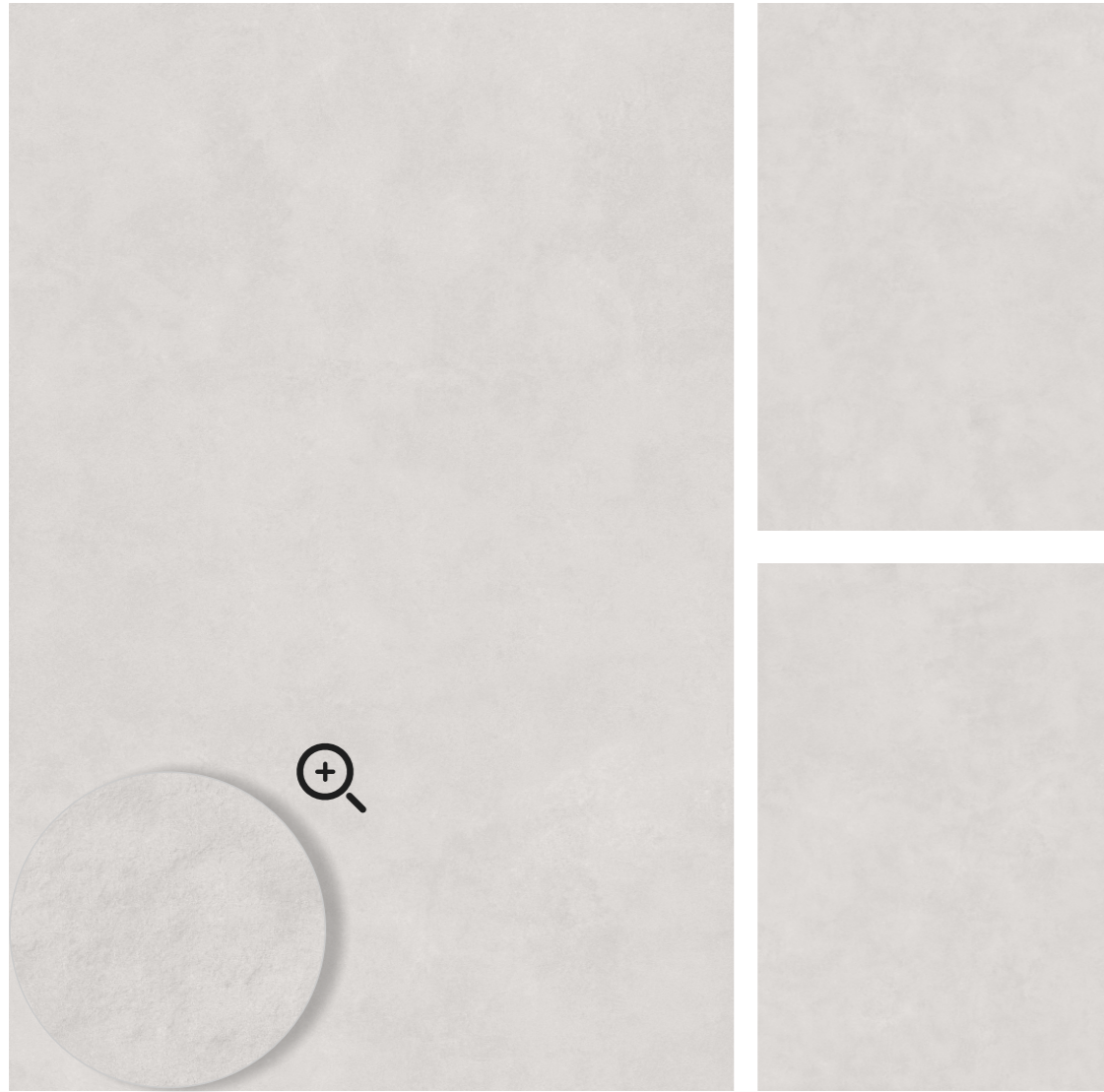

Tiles In Frame	Size	Finish	Thickness	Randoms
ROSATA BIANCO	1200x 1800mm	Fab Surface	9mm	3





ROSATA SERIES

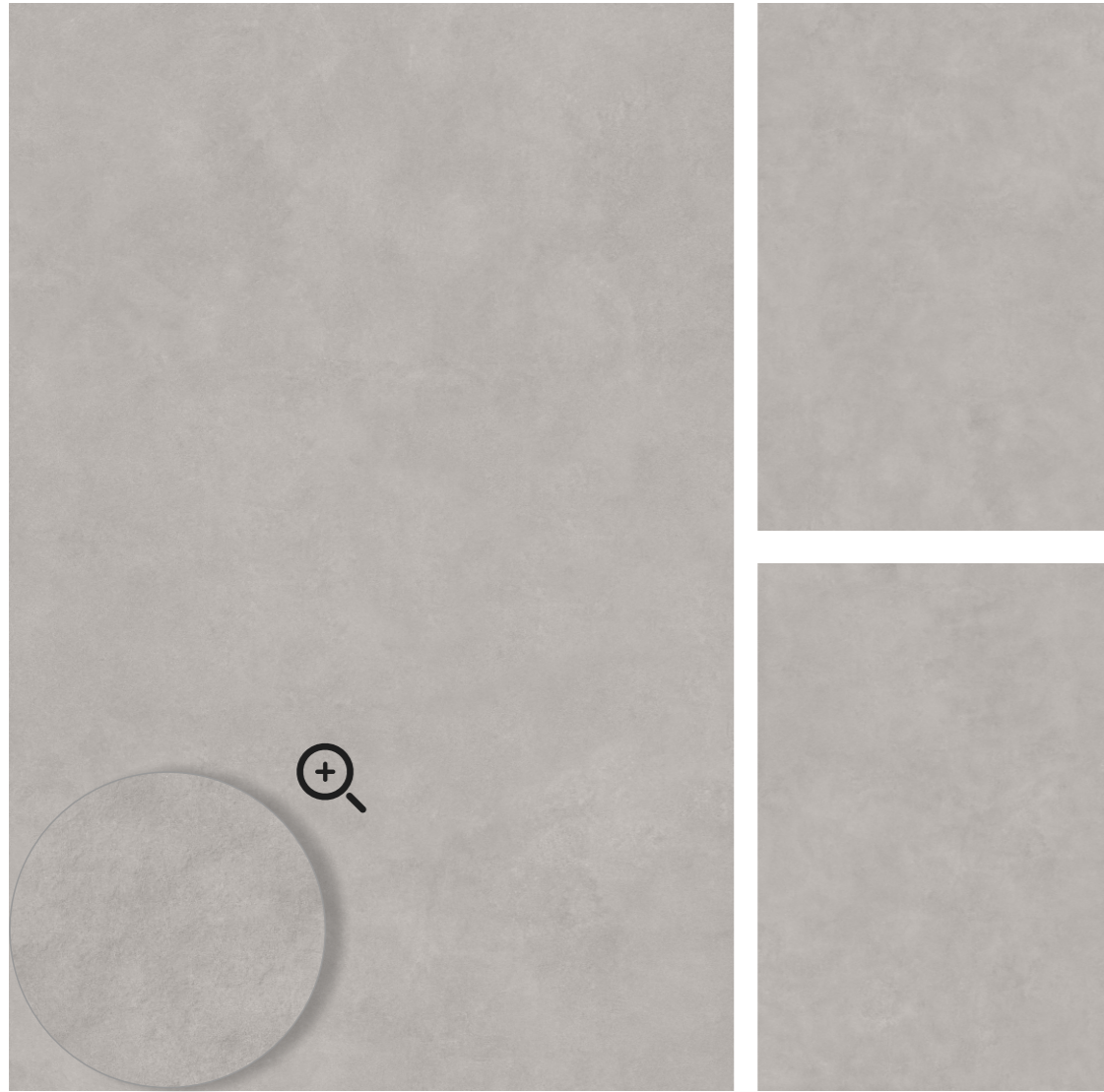

Tiles In Frame	Size	Finish	Thickness	Randoms
ROSATA GREY	1200x 1800mm	Fab Surface	9mm	3



LIQUID
REPELLENT



STAIN
RESISTANT



SCRATCH
RESISTANT



FIRE
RESISTANT



RESISTANT TO
UV RAYS



IMPACT
RESISTANT



FROST
RESISTANT



ROSATA
SERIES

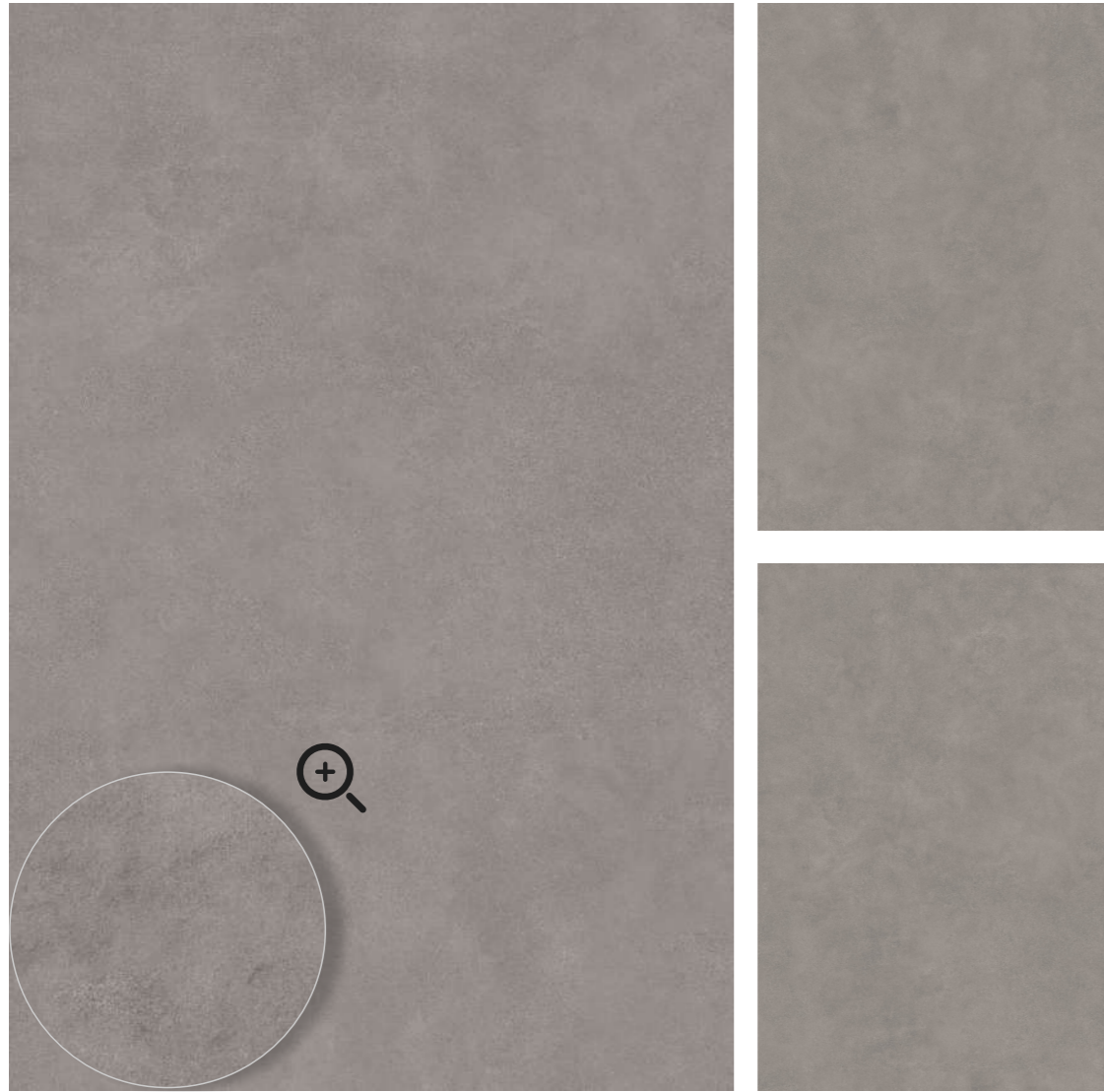

Tiles In Frame	Size	Finish	Thickness	Randoms
ROSATA GRIS	1200x 1800mm	Fab Surface	9mm	3

- 
LIQUID
REPELLENT
- 
STAIN
RESISTANT
- 
SCRATCH
RESISTANT
- 
FIRE
RESISTANT
- 
RESISTANT TO
UV RAYS
- 
IMPACT
RESISTANT
- 
FROST
RESISTANT



General Indication For Handling, Cutting And Laying

Handling

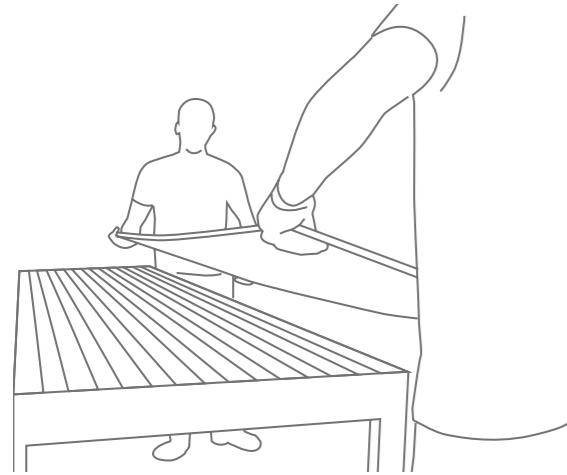

Where possible, mechanical lifting systems should be used for delivering slabs above the ground floor.

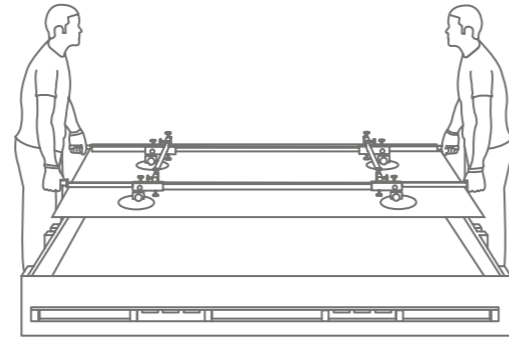

Handling the slabs on the floor can be managed with the aid of a frame fitted with suction cups to make the slabs more stable.

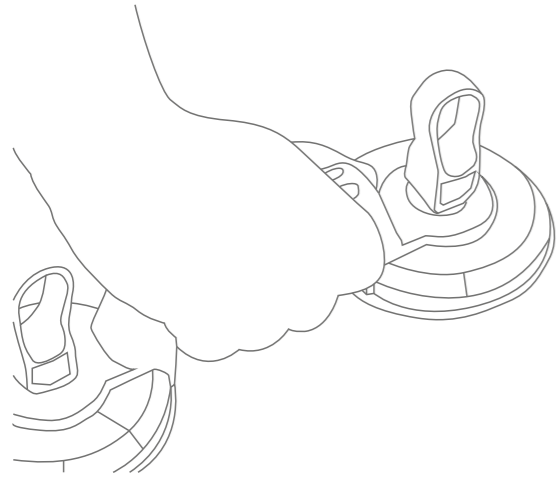

The appropriate suction cups may be used for manual handling.

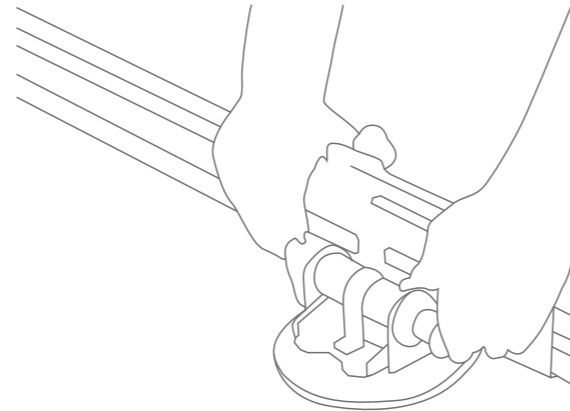

To facilitate handling of slabs with textured surfaces, the appropriate suction cups should be used.

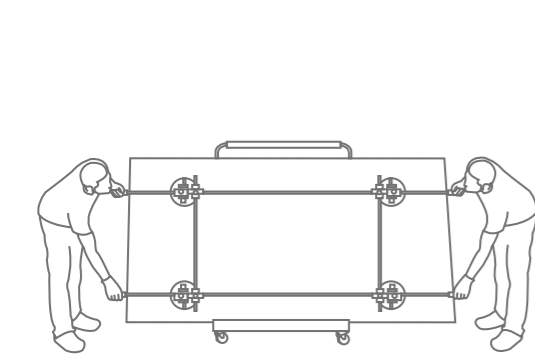

For moving the slabs over large surfaces, a forklift can be used.

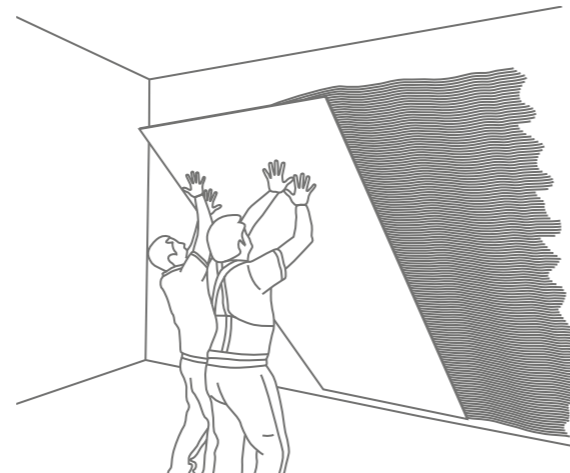

Once the slab is in position, excess air should be removed completely by tapping it either manually or mechanically using the appropriate trowel, starting from the centre and moving out towards the sides.

Cutting

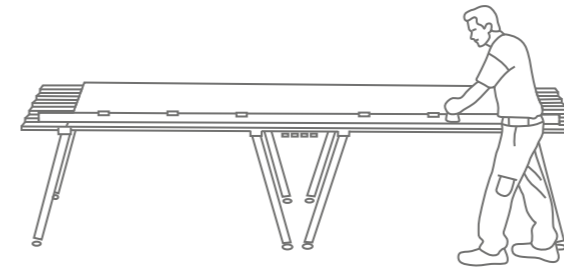

Cutting operations should be carried out on a perfectly stable, flat surface.

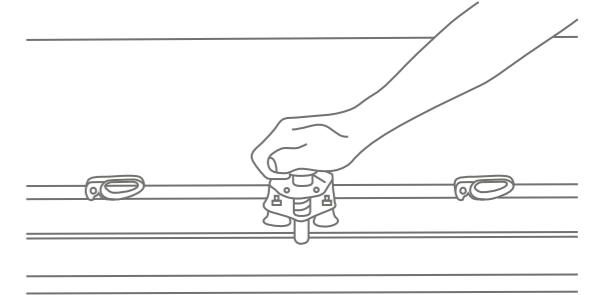

A cutting guide fitted with a diamond tip tool is recommended.

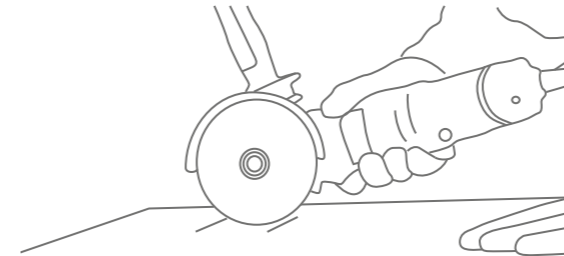

To cut the slab without breaking the material, the appropriate shears should be used.



The slabs can also be cut with a dry saw or wet saw with a diamond wheel cutter.

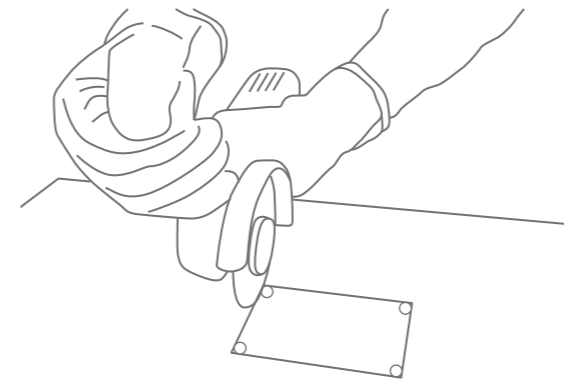

For L-shaped cuts or cuts inside the slab, holes should be bored at the vertices to prevent the blade of the cutting disk damaging the surface.

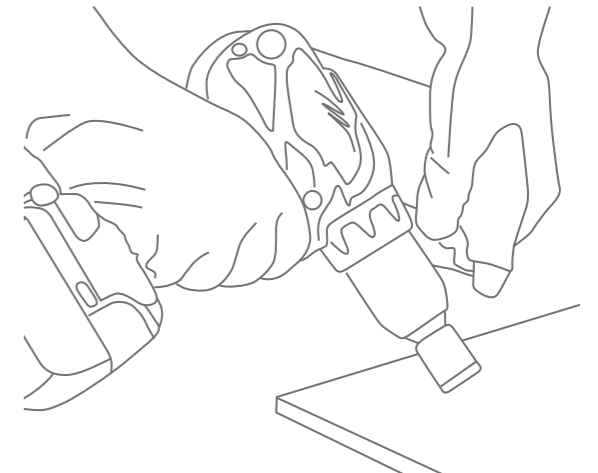

To bore cylindrical holes on the slabs, a diamond cutting tool of the desired diameter should be used, and the surface should be kept wet constantly.

TECHNICAL SPECIFICATION

TEST DESCRIPTION	TEST METHOD	ISO STANDARD 13006 B1a TILES	VALUE
Length and width	BS EN ISO 10545-2	± 0.6%	± 0.3%
Thickness	BS EN ISO 10545-2	± 5.0%	± 3.0%
Straightness of sides	BS EN ISO 10545-2	± 0.5%	± 0.3%
Rectangularity	BS EN ISO 10545-2	± 0.6%	± 0.3%
Surface flatness	BS EN ISO 10545-2	± 0.5%	± 0.3%
Water absorption	BS EN ISO 10545-3	≤ 0.5%	≤ 0.05%
Breaking strength	BS EN ISO 10545-4	≥ 1300N	≥ 1500N
Modulus of rupture	BS EN ISO 10545-4	≥ 35 N/mm ²	≥ 45N/mm ²
Resistance to deep abrasion	BS EN ISO 10545-6	≤ 175mm ³	≤ 150mm ³
Linear thermal expansion	BS EN ISO 10545-8	≤ 9 x 10 ⁻⁸ °C ⁻¹	≤ 7 x 10 ⁻⁶ °C ⁻¹
Thermal shock resistance	BS EN ISO 10545-9	No visible defect	No visible defect
Frost resistance	BS EN ISO 10545-12	Frost proof	Frost proof
Resistance to chemicals	BS EN ISO 10545-13	No visible effect	No visible effect
Resistance to stain	BS EN ISO 10545-14	Manufacturer to state class	Stains removed Min. Class 2
Colour resistance	BS EN ISO 10545-16	No damage	No damage
Colour resistance to UV Light	DIN 51094	No change in color	No change in color
Scratch hardness(MOH's Scale)	EN 101	≥ 6 MOHS	≥ 7 MOHS
Surface quality	BS EN ISO 10545-2	Min. 95%	No visible defect
Skid resistance (friction co-efficient)	BS EN ISO 10545-17	> 0.4	>0.4
Moisture Expansion	-	Nil	Nil



PACKING DEATILS

Size	Pcs / Box	Weight (Approx)	Thickness (Approx)	SQ. / Box
1200x1800	2	90 kg	9mm	46.50

Thank You